

Economy Machine

Affordable for every budget

TP-6000

The TP-6000 is an economical automatic strapping machine for wide straps (8 mm-15.5 mm). With proven quality and competitive price, it is the most cost effective solution for wide straps general purpose application.



15F-1, NO. 17, SEC. 1, CHENGDE ROAD,
TAIPEI 103, TAIWAN
TEL: 886 2 2555 2515
FAX: 886 2 2555 2516
WEB: www.transpakcorp.com
E-mail: transpak@transpak.com.tw

Made in Taiwan

11.2012x2000

Main Features

- Easy operation, simple maintenance.
- Mechanical outside tension control. Tension can be easily set with a dial.
- Affordable for every budget.

Options

- Short feed sensor
The sensor will detect whether the strap is at sealing position. If not, the start switch can not be activated.
- Stainless steel frame SUS 304 (TP-6000S)

Arch Sizes

H \ W	650	850	1050	1250
400				
600		Ⓢ		
800	N/A			
1000	N/A			
1200	N/A			

Ⓢ Standard size: 850 mm(W) x 600 mm(H)

- N/A means not available
- Larger arches on request

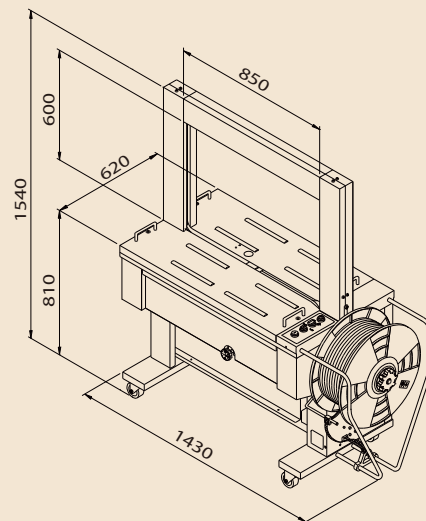

TP-6000 Technical Data

Strap Width 8 mm-15.5 mm

Strap Thickness 0.55 mm-0.75 mm

Strap Tension 10-70 kg

Speed Per Minute (60Hz) 27 straps

Net Weight 220 kg

Electrical Requirements

110V, 220V, 230V 50/60Hz 1PH
220V, 380V, 400V 50/60Hz 3PH



All specifications are subject to change without notice.